

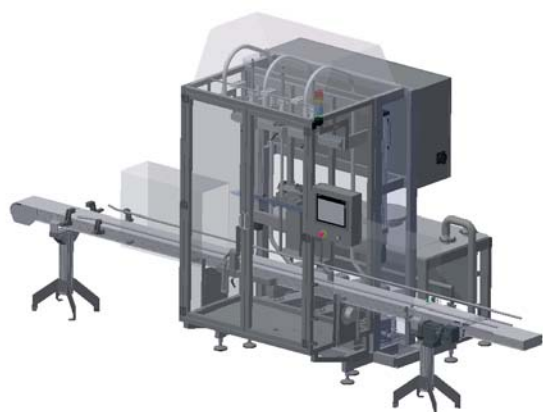

Trefill Compact Chem™



Trefill Compact Chem™ is a special version of Trepak's most compact machine Trefill Compact™ in the Trefill family of fillers. The machine fits in lines with lower capacity requirements and a production capacity of up to 45 packages per minute.

Trefill Compact Chem™ is best suited in production lines with a greater spread of different packaging volumes. The machine can handle packages with volumes from 100 ml up to 25 liter.

Trefill Compact Chem™ is available with one to three filling nozzles, and handles package sizes with heights up to 500 mm.

Trefill Compact Chem™ is suitable for installation in different industries, such as food and beverage, chemical, oil, and pharmaceutical.

Trefill Compact Chem™ is suitable for production lines and is compatible with various types of upstream and downstream equipment, such as capping machines and labeling machines.

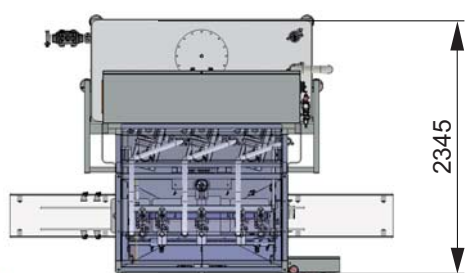
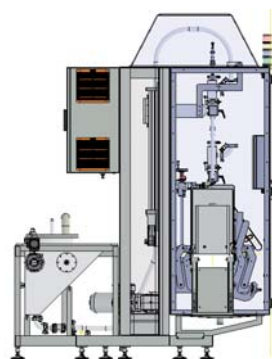
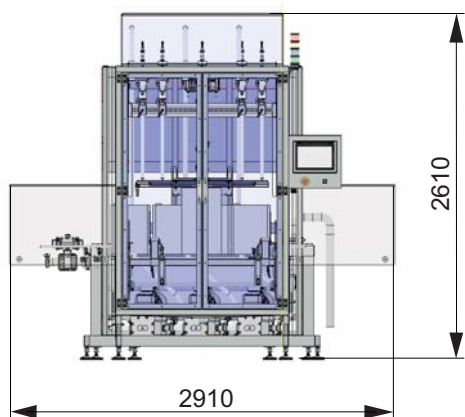

Measurements are approximate and may differ depending on configuration.

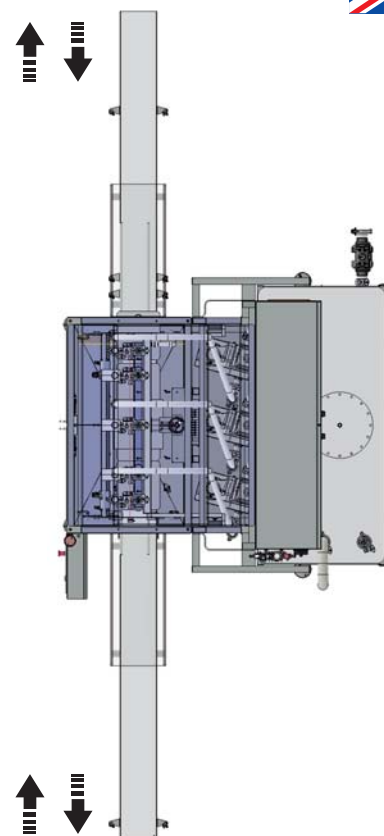
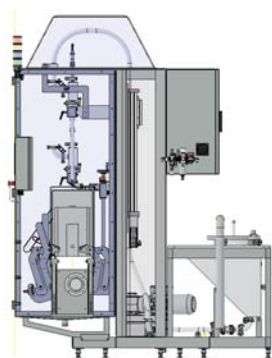
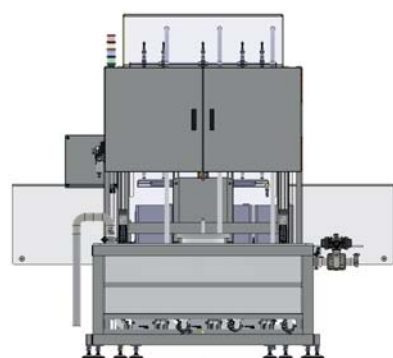

Possible directions of travel

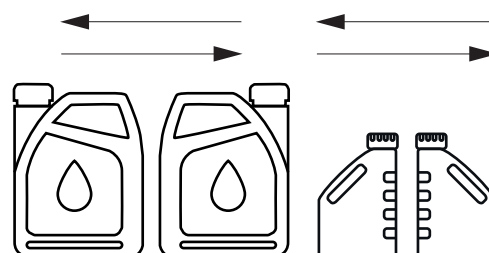

Technical data - Trefill Compact Chem™

Capacity per hour	Up to 2700 packages
Capacity per minute	Up to 45 packages
Power supply & Frequency	400 V AC + N & 50 Hz
Consumption (incl. conveyor)	5 kW
Air supply & Air flow	Min. 6 bar & Max. 50 L/minute
Standard conveyor height	800 - 1000 mm
Weight (excl. conveyor)	800 kg
Normal working temperature ³	10-30 °C

No. of filling nozzles	1-3
Tank volume ¹	150 L
Package WxHxL ²	Max. 300x500x350 mm

¹ Tank volume 150 L in the standard version. May vary depending on requirements. Product feeding is also possible directly from an external product container.

² Other dimensions are available on request.

³ Contact us in case of questions.

* For other requests, e.g. ATEX, please contact us.

TDS-Trefill Compact Chem-v03-EN

Trepak International AB designs, builds, installs, and maintains filling machines for liquid products, and capping machines for all types of packages. The company is based in Malmö, Sweden. Our solutions are always adapted to each customer's specific needs. Assembly, service, and maintenance are carried out by our in-house staff. One major customer is Tetra Pak. Many of their packages are capped by machines that we have developed, manufactured, and delivered.



Trepak International AB
Kantyxegatan 9
SE-213 76 Malmö, Sweden

Phone +46 40 18 07 00
www.trepak.se
info@trepak.se